

Peel Test Fixture

90 Degrees with optional angle adjustment

- laminated surface coatings
- films
- packaging and rigid backings

The G50 test fixture is ideal to test inflexible adherends for which a 180 ° peel test is not suitable because of the cracking, breaking or delamination of the adherend. The robust fixture also applies to testing high strength adhesives and capable of loads to 10 kN (2250 lb).

The bonded sample assembly is prepared and the two adherends pulled apart at a steady rate, starting at the open end of the bond. Separation occurs progressively along the length of the bonded adherends. The fixture is attached to the machine crosshead with cabling that ensures the lateral table movement is constant and independent of sample behavior. The standard G50 ensures a constant 90° angle occurs throughout.

Force is normal to the plane of the bond through the separated part of the flexible adherend. An upper grip is required (optional) for the flexible adherend. Test machine adapters are available to match your machine.

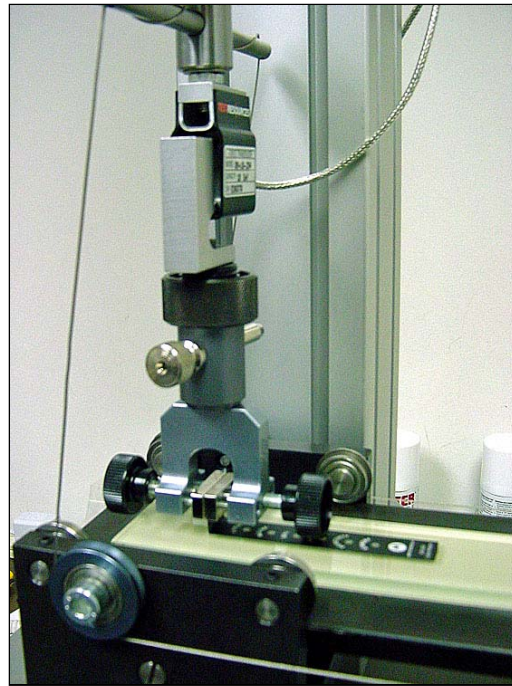
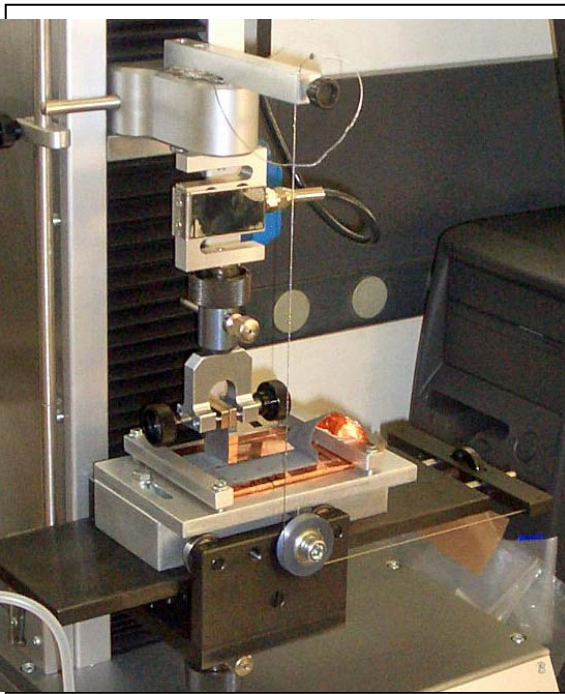

Standard G50 90 degree Table with cable to upper machine crosshead and G227 upper grips



G50 90 degree



G50-130 Width 130 mm (5.1")



G50-260 Width 260 mm (10.2")
With crosshead cable & adapters

Description

G50 fixtures consist of a table mounted in upper and lower low friction bearings, which is fixed by cable to the moving test machine crosshead using a supplied wire and pulley. As the crosshead moves up, the cable pulls the G50 table laterally to maintain a constant 90° angle peel.

The 90° angle peel fixture measures the bond strength between laminated surface coatings, films, packaging, and their rigid backings, as well as other bonded structures.

The force required to peel the laminate is monitored by the load cell, providing a direct measurement of bond

Example Test Methods - G50 Fixture

ASTM D6862 Standard Test Method for 90° Angle Resistance of Adhesives to measure the resistance-to-peel strength of an adhesive bond between one rigid adherend and one flexible adherend when tested at an angle of approximately 90 degrees under specified conditions of preparation and testing.

ASTM D6252 Peel Adhesion of Pressure-Sensitive Label Stocks at a 90° Angle covers the measurement of peel adhesion of pressure-sensitive label stocks. The test measures adherence to a standard steel substrate or other surfaces of interest for a pressure-sensitive label stock.

ASTM D2861 Flexible Composites of Copper Foil with Dielectric Film or Treated Fabrics covers procedures for peel testing flexible copper foil combined with dielectric film or treated / impregnated fabric to form flexible composites used in the manufacture of flexible or multilayer circuitry.

Dimensions of Standard G50 Peel Fixture

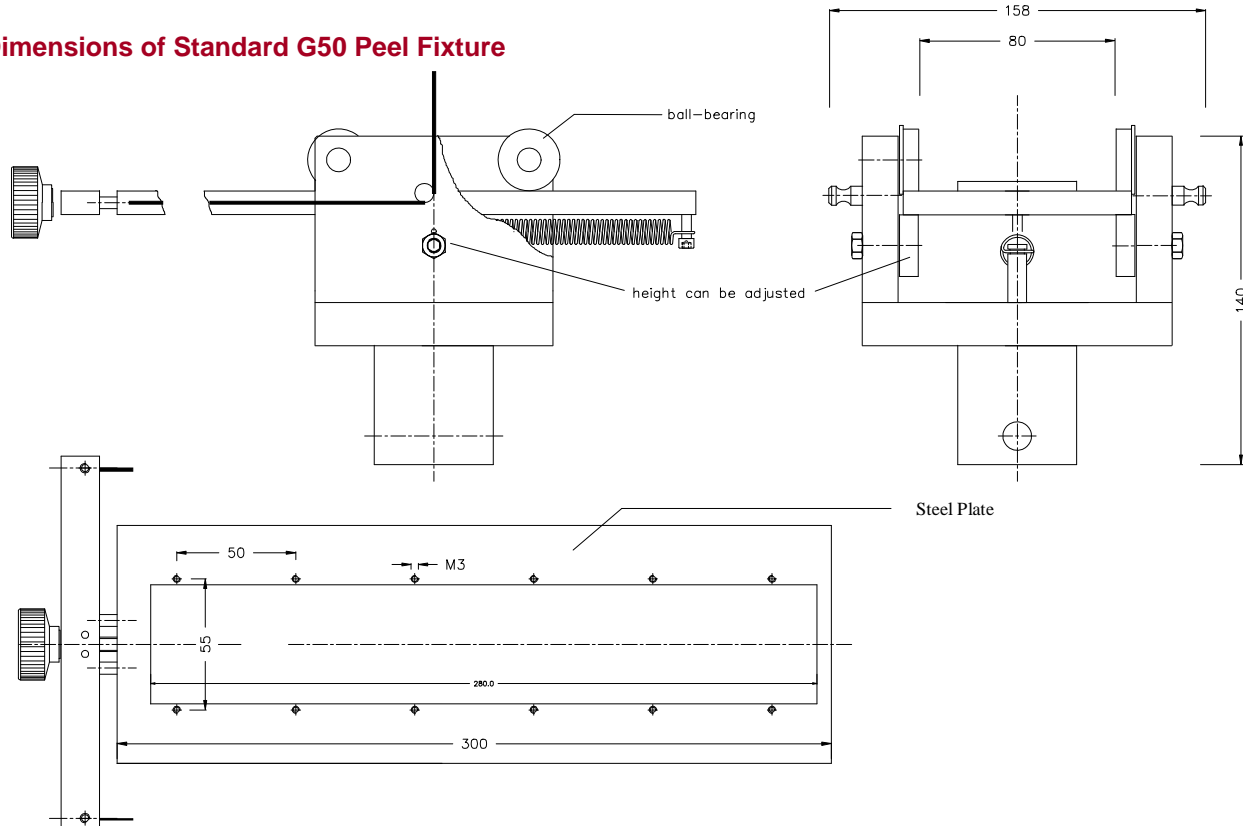

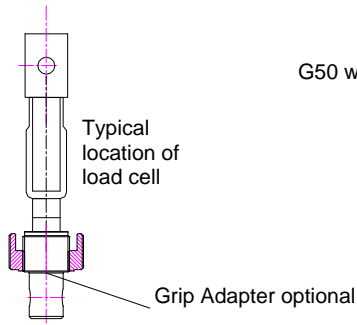

G50 wire and pin included

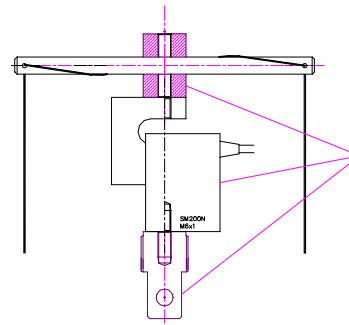

G50 does not include adapters nor load cell

Setup of Fixture in test machine

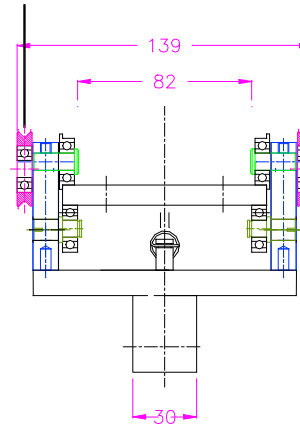

Ordering Information

G50 – Full fixture with 55 mm wide base

G50-100 – 100 mm wide base

G50-ADJ – 55 mm wide base with adjustable angle

Select Coupler to machine

Select Upper Grip

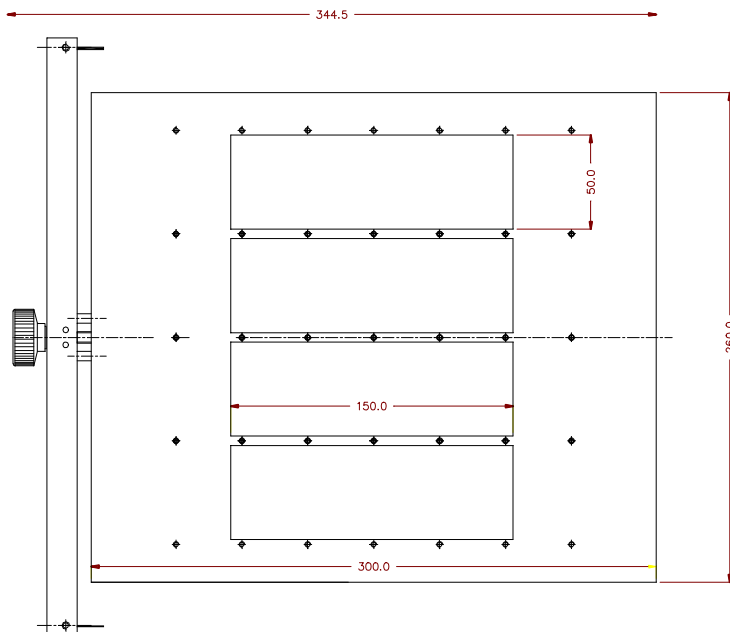

Wide Width G50B260L300
for large samples.

G50ADJ30 – Adjustable Angle Base - from 90 to 30 degrees.

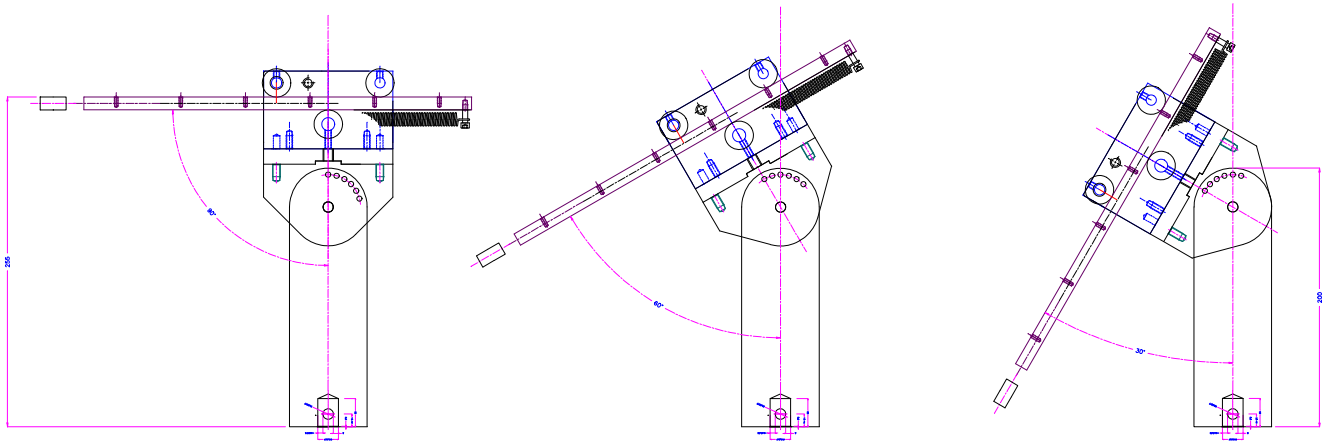

G50ADJ120 – Adjustable Angle Base - 90 +/- 30 degrees.

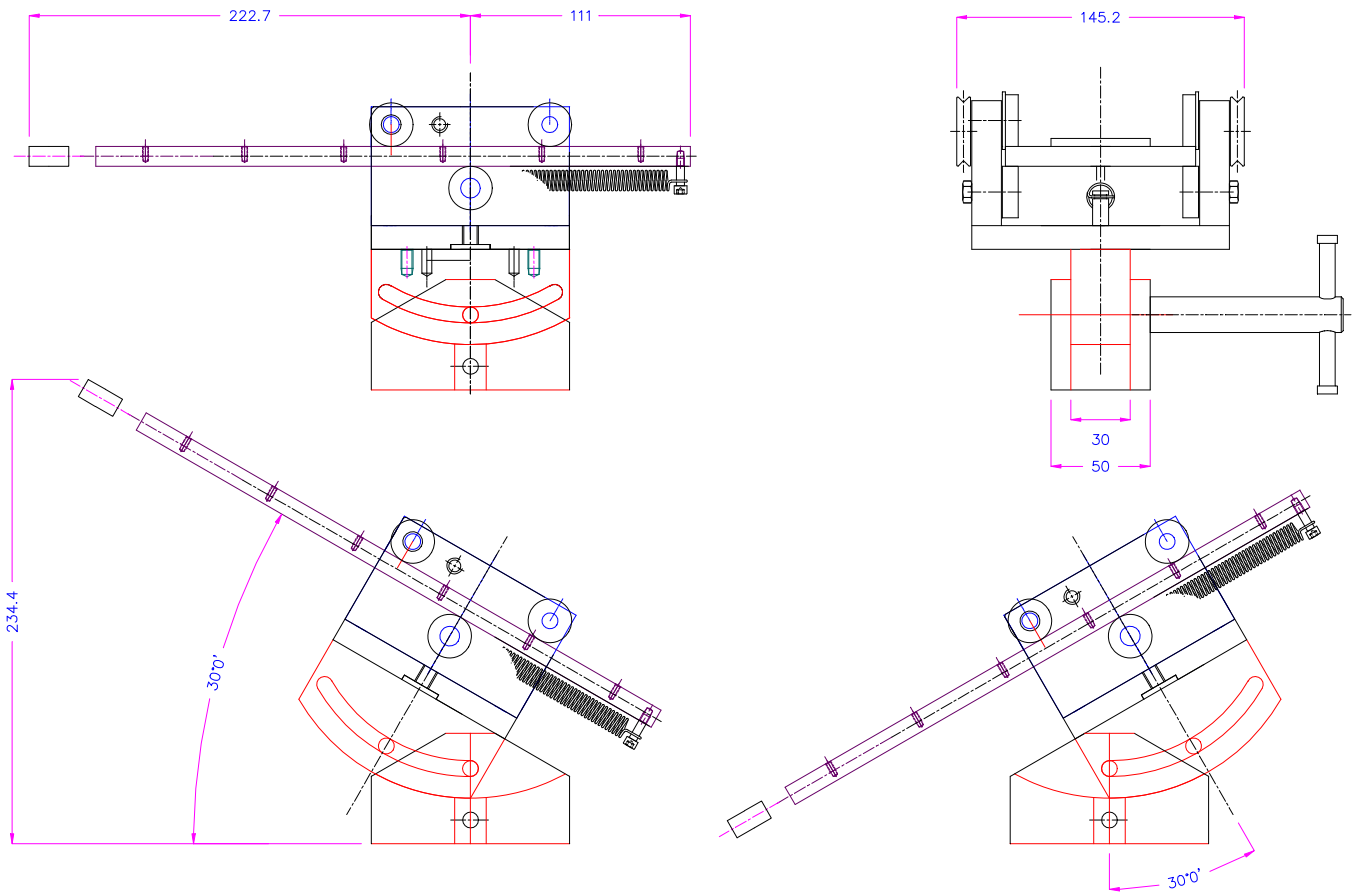

Other 90 Degree Fixtures



Model G3 -- Free spinning German wheel for flexible adherends. Several sizes – also built to order.

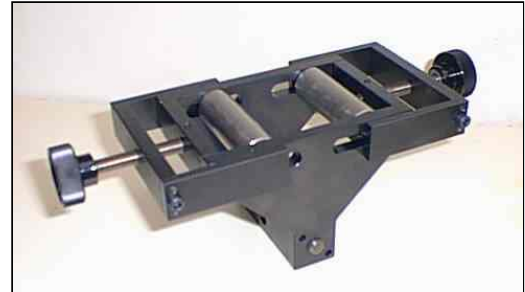

Model G192 -- 90 degree pull for flexible adherends pulled from flat rigid samples such as PC boards.